

INSTALLATION INSTRUCTIONS

Lend-A-Hand Banister Rail

AR-42, AR-50



RV Handrail

Models: AR-42

42" handrail length, 38° angle

AR-50

50" handrail length, 38° or 45° angle

Contents

- (1) Handrail assembly
- (4) 1-1/2" mounting screws
- (4) 1" mounting screws
- (2) Weatherproof stickers

Tools Required

- Drill and 1/8" drill bit
- Phillips screwdriver
- Cutting tool
- Silicone caulk
- Tape measure

WARNING: This rail will help you maintain your balance. It is not designed to break your fall, but instead prevent it. Always maintain contact with this rail when entering and leaving your RV.

Space Required for Installation

Some RVs have windows, slide outs, awning arms or fold out step well trim that may interfere with the handrail bracket placement. Prior to attempting installation, check your RV to ensure ample space is available. **Bottom hinged bracket must be secured into hardwood floor board.**

AR-42 is designed for double and some triple steps.

AR-50 is designed for some triple and all quad steps.

NOTE: AR-50 extends 10.9" below entry floor level. Most appropriate for RVs with at least 11" skirting.

See page 2 for more dimensions.

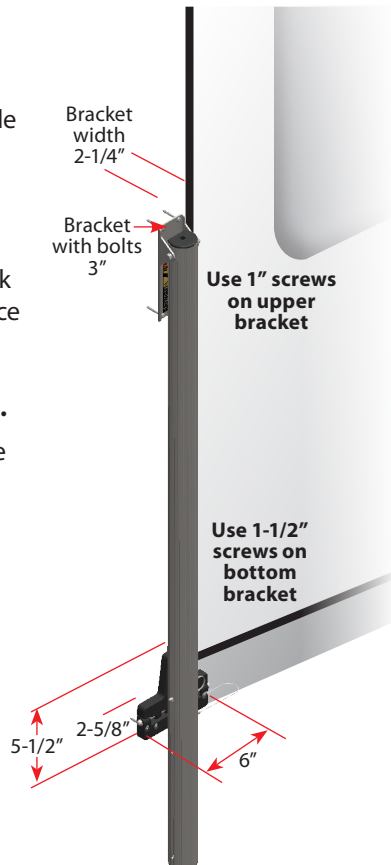

Installation

1. Remove existing handrail. Clean away any debris and caulk holes to prevent water leakage.
2. To lock the handrail in its closed position and prevent it from opening during installation, slide lock pin through the support rod tab and insert cotter pin through the locking pin hole. (See **Figure 1**)

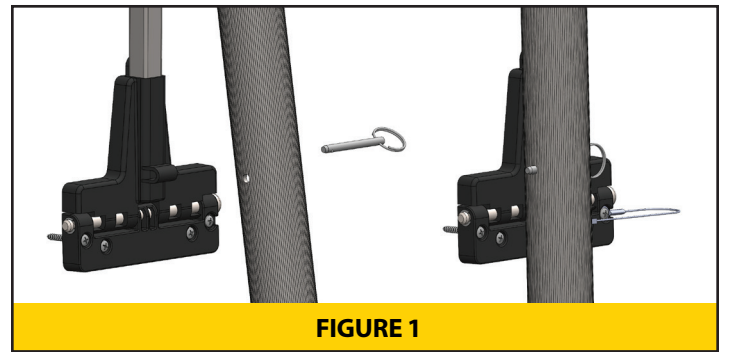

3. Hold AR-42/AR-50 in position, placing bottom bracket next to the left side of door frame and lining up with bottom of the door frame. A section of your RV's trim piece may have to be removed to provide a flat surface for rail installation. If necessary, carefully score and cut trim without cutting into RV siding.

Patent Pending INS-AR4250-C 07.16.2024

4. Using brackets as a guide, mark mounting hole locations and drill pilot holes into RV. Caulk holes prior to attaching rail.

5. With holes caulked, hold rail in position and attach with screws into the pilot holes you created in step 4. Start with the top 2 (1") screws, then the **4 (1-1/2") bottom screws, securing hinge bracket into hardwood floor board.** Make sure to attach lanyard to lower right screw.

6. Remove locking pin; deploy rail to expose upper mounting holes. Install remaining 2 (1") upper screws. (See **Figure 2**)

7. A durable, weatherproof sticker is provided to cover any exposed holes from previous handrail. Caulk holes prior to applying sticker. Awning arm may have to be extended to apply sticker.

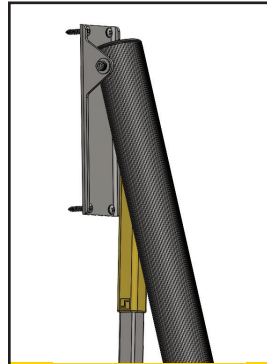

FIGURE 2

Operation

1. Pull locking pin to release rail. Grab the yellow rubber grip to slide rail into position.

2. Insert locking pin through hole to lock rail into position.

3. AR-50 can be positioned at a 38° or 45° angle. (See **Figure 3**)

4. During travel, fold and lock rail securely against side of RV. Be sure locking pin slides through tab on support rod.

If you are having trouble replacing the pin, rotate it clockwise and counter clockwise with some pressure to replace it and lock the rail in place.

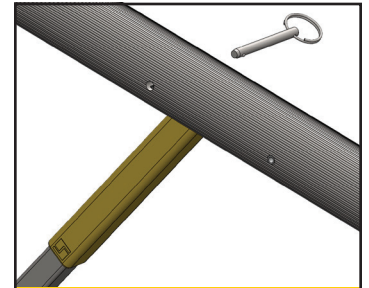
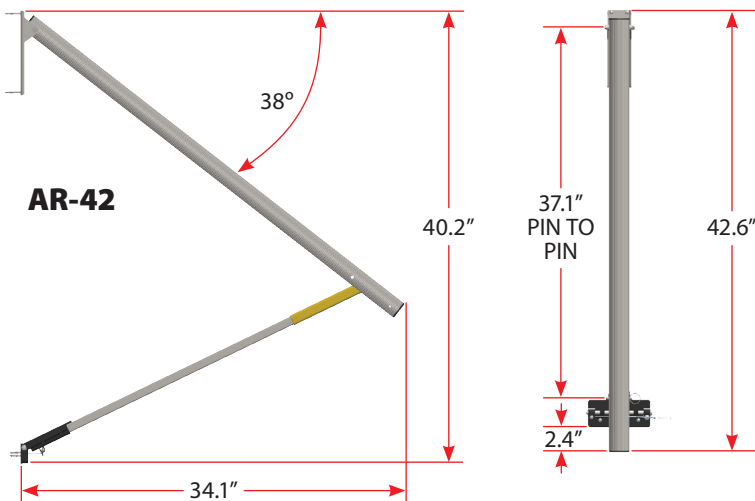

FIGURE 3



WARNING
This product can expose you to chemicals including lead, which is known to the State of California to cause cancer and birth defects or other reproductive harm. For more information, go to www.P65Warnings.ca.gov.

